

Nov. 8, 1932.

E. J. QUINBY  
SOUND REPRODUCER  
Filed Feb. 20, 1929

1,887,185

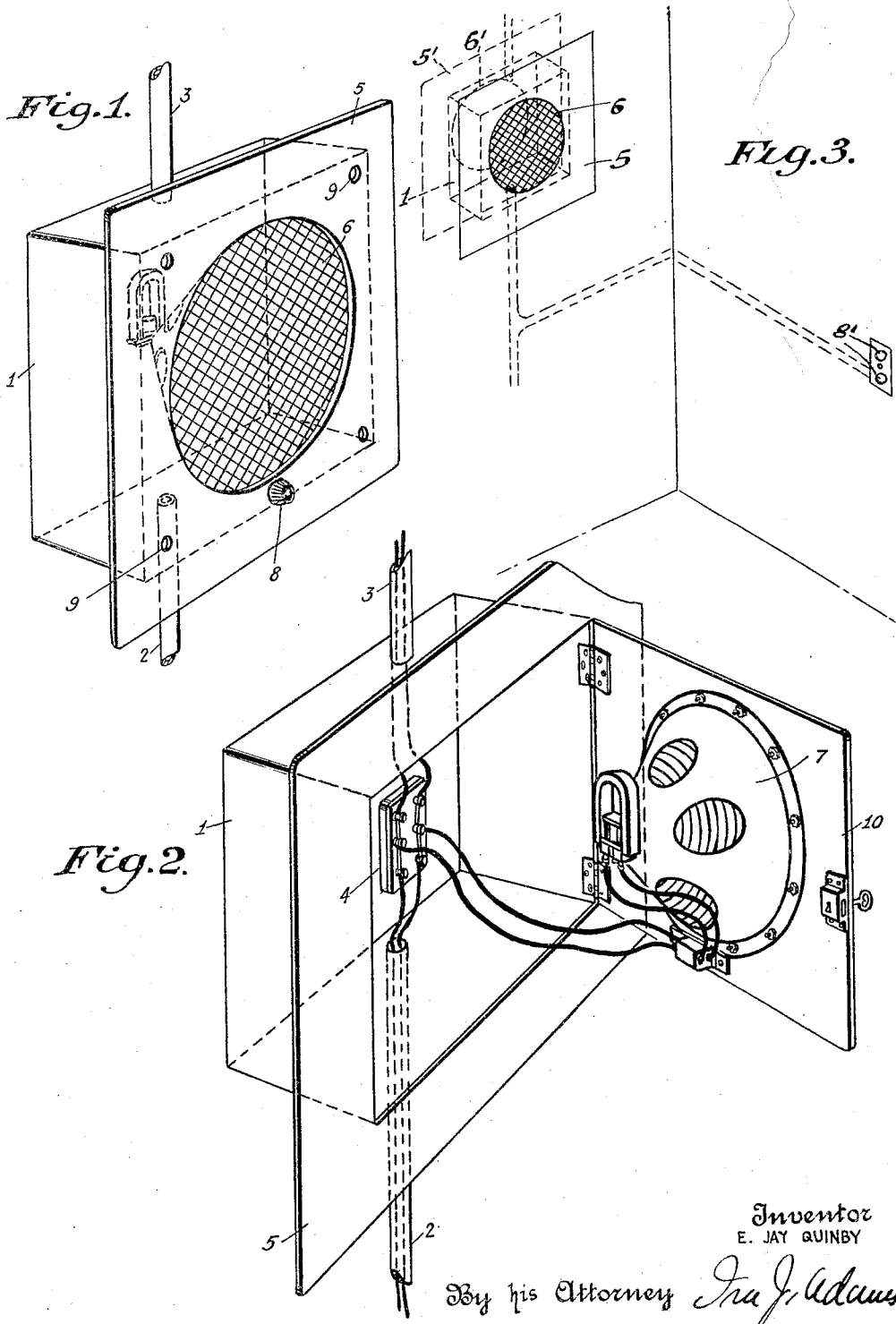

Inventor  
E. JAY QUINBY

By his Attorney *Ira J. Adams*

# UNITED STATES PATENT OFFICE

EDWIN JAY QUINBY, OF YONKERS, NEW YORK, ASSIGNEE TO RADIO CORPORATION OF AMERICA, A CORPORATION OF DELAWARE

## SOUND REPRODUCER

Application filed February 20, 1929. Serial No. 341,337.

This invention relates to sound reproducers of the type known as loudspeakers and means for mounting the same. More particularly, this invention relates to the mounting of loudspeakers in the walls or ceilings of apartment house or hotel rooms where a centralized radio receiving system is in use, and still more particularly to the housing structure which is built into the walls or ceilings of such rooms.

The object of this invention is to provide a simplified structure for housing the loudspeakers, which is relatively cheap to manufacture and which is readily installed when the apartment house or hotel is being erected.

An approved form of my invention is described in the following specification which should be read in connection with the accompanying drawing in which:

Figure 1 illustrates a relatively simple form of the structure which I propose to use,

Figure 2 illustrates a modification thereof, and

Figure 3 illustrates diagrammatically the proposed structure mounted in a wall of the room with control means therefor mounted on another wall of the room.

Referring more particularly to the drawing, the housing structure comprises a box-like member 1 which is provided with an inlet conduit 2 and an outlet conduit 3. The member 1 may be made of metal, wood or any other suitable material and its construction is preferably such that it does not have a natural resonant period within the audible range. In some instances, however, it may be desirable to accentuate some frequencies and in such cases the member 1 may be provided with means adapted to form a plurality of resonating chambers. The inside of the member 1 may be covered with sound absorbing material such as acoustic felt, if it is desired to damp the sound waves radiated from the rear of the diaphragm.

The inside of the box-like member is adapted to contain a suitable housing 4 for the splices which are made in the conductors led to and from the box-like member by means of conduits 2 and 3. The housing 4 may also contain test terminals, emergency dis-

connecting devices, fuses, volume control and program transfer switches, and other associated equipment.

During the erection of the building the conduits 2 and 3 are built into the walls and the box-like member 1, is placed so that its front edge is flush with the wall surface. The plaster is then applied to the wall up to the edge of the box-like member. A cover plate which is preferably made somewhat larger than the box-like member so that it will extend beyond the edges of the box and thereby cover the rough joint where the plaster or finishing material joins the edges of the box, is provided for the member 1.

The cover plate which is indicated by reference character 5, may be either ornamented or plain, as desired. It is adapted to be fastened to the box-like member in any approved manner such as by bolts or screws extending through the cover plate and into the edges of the box-like member. The cover plate is provided with an opening approximately the size of the loudspeaker proper and the opening is preferably covered by a grille or screen to protect the loudspeaker from dust and dirt. A loudspeaker indicated generally at 7 is connected to the inside of the cover plate so that it fits into the box-like member when the cover plate is fastened in place.

A volume control knob 8 may be mounted on the cover plate as shown or, if desired, extensions may be provided for placing the volume control knob at some other point in the room. A program transfer switch or any other form of control device may also be mounted either on the cover plate or at a more suitable point within the room. A switch for controlling the operation of the speaker may also be located elsewhere within the room.

The box-like member 1 is normally closed at the back and for this reason it is usually advantageous to provide small apertures 9 in the cover plate to relieve the air pressure within the box. These apertures are usually made sufficiently small so that the sound waves radiated from the rear of the diaphragm are suppressed even though the air back of the diaphragm is not confined sufficiently to result

in objectionable damping. However, in some cases, the apertures may be made sufficiently large to utilize the sound waves radiated from the rear of the diaphragm, in the same room or in an adjoining room.

5 In cases where the loudspeaker is located in the wall between two rooms it may be found desirable to provide an opening in the back of the box-like member 1 to form a communication with the other room. In such an arrangement the sound waves radiated from the front of the diaphragm are projected into one room while those radiated from the rear of the diaphragm are projected into the other room. Thus, one loudspeaker is adapted to provide music to both rooms. In this case it may be well to provide a shutter in each room which can be manually operated to shut off the communication between the loudspeaker and that room. A volume control knob and a station selector switch may be placed in each room if desired.

In the modification illustrated by Figure 2 the cover plate 5 is provided with a hinged portion 10. The loudspeaker is attached to the hinged portion as shown thereby affording a relatively easy way of examining the interior of the box 1 after the loudspeaker has been installed and connected for operation. A lock may be provided on the hinged portion 10 so that unauthorized persons will be prevented from gaining access to the loudspeaker.

Figure 3 illustrates the box-like member mounted in one wall of a room with an opening in the rear of the box-like member for permitting sound waves from the rear of the diaphragm to be directed into an adjoining room. The box-like member is indicated diagrammatically at 1. It has the usual front cover plate 5 and a similar rear cover plate 5' on the wall of the adjacent room. The front cover plate 5 has the usual opening 6 and the rear cover plate 5' has a similar opening 6'. For the sake of clearness the loudspeaker per se is not shown in Fig. 3, but it is to be understood that it is mounted on the front cover plate 5 in the same manner as shown in Figures 1 and 2. In this modification suitable control knobs 8' are mounted on a different wall of the room from the loudspeaker.

The loudspeaker may be built into a wall or ceiling as desired and it may be operated from a centralized radio receiving system or directly from a radio receiving set in the usual manner. If desired two or more loudspeakers may be built into the same room and they may be connected to operate separately or at the same time.

60 It is to be understood that there are various other structural modifications which come within the spirit of my invention and I do not wish to be limited by the structure disclosed by the two figures of the accompanying drawing which illustrate preferred forms of

my invention, but only by the scope of the appended claims.

I claim:

1. A housing for a sound reproducer comprising a box-like member adapted to be positioned within a wall, a detachable cover plate secured to said box-like member and covering an entire side thereof, an opening in said cover plate, and a sound reproducer fastened to the inside of said cover plate adjacent said opening.

2. In combination, a box-like structure adapted to be positioned within a wall, a cover plate for said box-like structure, said cover plate extending past the edges of said structure, an opening in said cover plate, and a loudspeaker positioned in said box-like structure and fastened to said cover plate adjacent said opening.

3. The combination of a box-like structure adapted to be positioned within a wall with its edges flush with the surface of the wall, a cover plate secured to said box-like structure for covering the area defined by said edges, a hinged portion in said cover plate, an opening in said hinged portion, and a loudspeaker fastened to the inside of said hinged portion adjacent said opening.

4. In combination, a box-like member adapted to be built into a wall, a cover plate for said box-like member, an opening in said cover plate, a loudspeaker fastened to the inside of said cover plate adjacent said opening and a plurality of apertures in said cover plate.

5. The combination of a box-like member adapted to be built into a wall, a cover plate for said box-like member, said cover plate extending past the edges of said box-like member, a hinged portion in said cover plate, an opening in said hinged portion, a loudspeaker fastened to the inside of said cover plate adjacent the opening in the hinged portion, and means on said cover plate for controlling the operation of said loudspeaker.

6. A housing for a sound reproducer comprising a box-like member adapted to be positioned within a wall, said box-like member having an opening therein defined by edges, a cover plate of larger area than that of said opening secured to said box-like member, to cover said opening and extend beyond said edges, an opening in said cover plate, and a sound reproducer positioned within said casing with its diaphragm adjacent the opening in said cover plate.

7. Acoustic apparatus comprising an enclosure adapted to be positioned within a wall with one edge substantially flush with the surface of the wall, a cover plate for said enclosure adapted to be secured to the edge thereof substantially flush with the surface of the wall, said cover plate being larger than the area defined by said edge whereby it covers the junction of the wall and said edge,

an opening in said cover plate and a loudspeaker supported within said enclosure with its diaphragm adjacent said opening.

5 8. Acoustic apparatus comprising an enclosure adapted to be positioned within a wall with one edge substantially flush with the surface of the wall, a cover plate for said enclosure adapted to be secured to the edge thereof substantially flush with the surface  
10 of the wall, an opening in said cover plate, a loudspeaker supported within said enclosure with its diaphragm adjacent said opening and an opening in the rear of said enclosure to provide communication between the interior of said enclosure and the room on the  
15 other side of said wall.

9. In combination a room having a plurality of walls, an enclosure adapted to contain a sound reproducer mounted in one of  
20 said walls, an opening in said enclosure communicating with said room, a sound reproducer mounted in said enclosure adapted to radiate sound through said opening into said room and control means for said sound re-  
25 producer mounted on another wall of said room.

EDWIN JAY QUINBY.

30

35

40

45

50

55

60

65